

Mobile Dual Screen System - Fixed Height

The TouchBoard Mobile Dual Screen System is engineered from high tensile steel and rigid aluminium materials and designed to support two modern LED touch panels up to 136kg. This system provides a modern addition to any corporate, boardroom or education environment.

Sturdy and robust and able to support dual LED touch panels up to 75".

Modular in design, this system can convert to the Wall Mount or Free Standing Dual Screen System providing the ability to adjust with the changing needs of the customer.

Available in fixed height, with mechanically adjustable to provide added flexibility and inclusive access for mixed or shared learning spaces. A central laptop tray is included as standard. Options include a side laptop tray, keyboard, PC and webcam mount as well as a lockable AV cabinet.

- ✔ Designed to provide complete flexibility in any learning / presentation area
- ✔ Provides inclusive learning for mobility impaired users
- ✔ Modular in design, being able to be converted to a Wall Mount or Free Standing Dual Screen System
- ✔ Sturdy and robust simple mechanical height adjustability
- ✔ Easy to manoeuvre between areas and pack away when not required
- ✔ Central laptop tray and webcam included. Webcam, keyboard and lockable AV cabinet available.
- ✔ Integrated power distribution board with surge protection
- ✔ Fast and easy installation process, taking under 1 hour

Height Adjustable



Panel Sizes



Dimensions Front

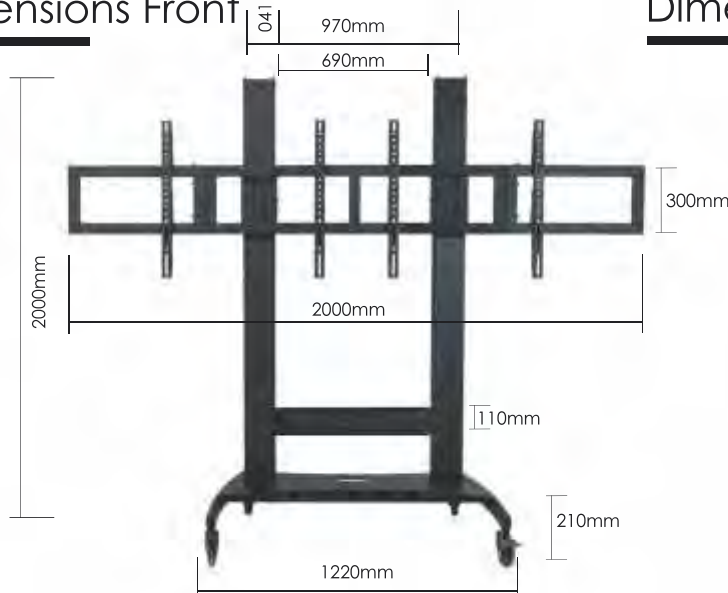

Dimensions Side



Accessories



Front Laptop Tray



Side Laptop Tray



Keyboard Mouse Bracket



Mini PC Bracket



Web Cam Bracket



Lockable AV Cabinet

Specifications

Frame Specifications	
Dimensions	Width - 2000mm Columns 970mm
	Height of Frame - 2000mm
	Width of Base – Front 1220mm Rear 920mm
	Depth of Base – 750mm, Castors - 100mm PU with Brake
Material	Aluminum Extrusion Legs 2.5mm
	Steel Plate Support Brackets 3.0mm
Finish	Surface Treated Powder Coating Texture Finish to 2.0mm Thickness
Height Range	1270mm Mechanical Adjustment
Lifting Design	Nil
Weight Supported	Up to 136kg
VESA Supported	400mm x 400mm up to 1200mm x 600mm

Packing Dimensions			
Item no.	Descriptions	Packing Dimensions (mm)	Weight (kg.)
1	Frame	2035 x 390 x 130	26
2	Extrusions	1910 x 320 x 190	23
3	Base	1280 x 850 x 100	25

Electrical Specifications	
Linear Actuator	Nil
	Nil
	Nil
	Nil
	Nil
	Nil
	Nil
	Nil
	Nil
	Nil
Control Box	Nil
	Nil
	Nil
	Nil
Switch	Nil
	Nil
	Nil
Power Board	4 Way PDU Aluminum Rack Mount CE.

