

## Mobile Height Adjustable System - Actuator Lift

The TouchBoard Mobile Height Adjustable System with Actuator Lift is engineered from high tensile steel and rigid aluminium materials and designed to support modern LED touch panels up to 136kg. Using a single linear actuator, this system provides a modern addition to any corporate, boardroom or education environment.

Sturdy and robust and able to support larger 86" and 98" LED touch panels. Modular in design, this system can convert to the Wall Mount or Free Standing Height Adjustable System providing the ability to adjust with the changing needs of the customer.

Available in motorised, electric height adjustable to provide added flexibility for mixed or shared learning spaces. A central laptop tray is included as standard. Options include a side laptop tray, keyboard, PC and webcam mount as well as brackets to support VESA mounts up to 1470mm.

- ✔ Designed to provide complete flexibility in any learning / presentation area
- ✔ Provides inclusive learning for mobility impaired users
- ✔ Modular in design, being able to be converted to a Wall Mount or Free Standing System
- ✔ Sturdy and robust with simple electronic actuator control
- ✔ Easy to manoeuvre between areas and pack away when not required
- ✔ Central laptop tray and webcam mount standard inclusion
- ✔ Integrated power distribution board with surge protection
- ✔ Fast and easy installation process, taking under 1 hour

### Height Adjustable

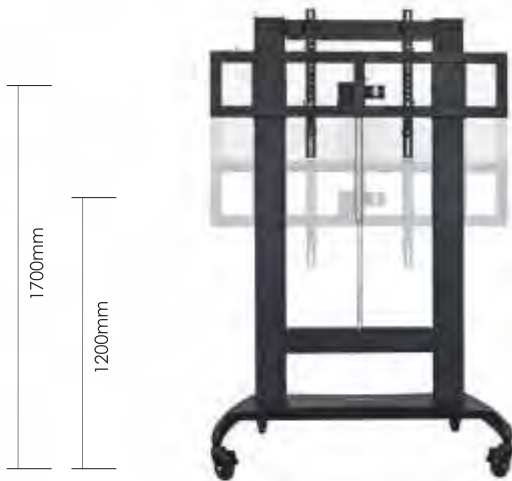

### Panel Sizes

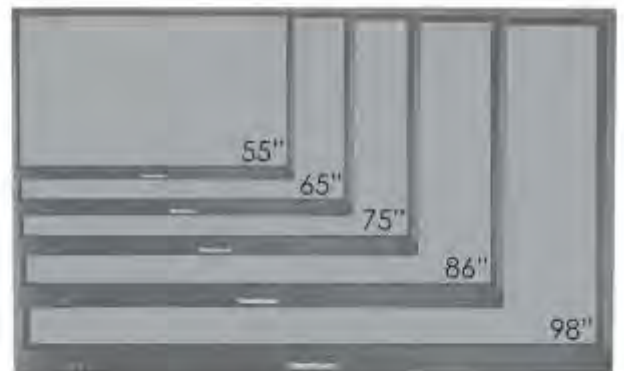

### Dimensions Front

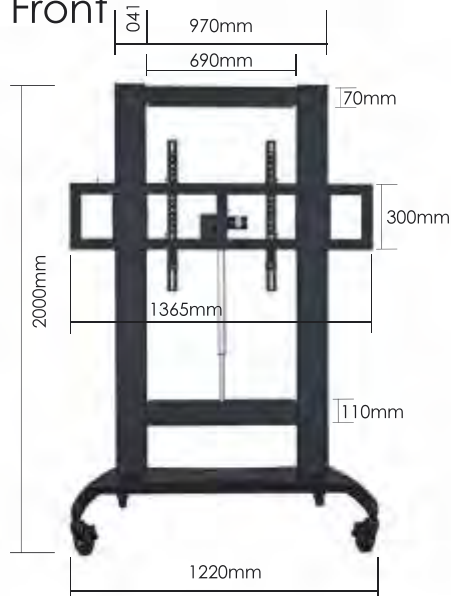

### Dimensions Side



# Accessories



Front Laptop Tray



Side Laptop Tray



Keyboard Mouse Bracket



Mini PC Bracket



Web Cam Bracket



Extension Brackets to support VESA to 1470 x 870mm

# Specifications

Frame Specifications	
Dimensions	Width - 1365mm Columns 970mm Height of Frame - 2000mm Width of Base - Front 1220 Rear 920mm Depth of Base - 750mm, Castors - 100mm PU with Brake
Material	Aluminum Extrusion Legs 2.5mm Steel Plate Support Brackets 3.0mm
Finish	Surface Treated Powder Coating Texture Finish to 2.0mm Thickness
Height Range	Up / Down - 500mm of Travel
Lifting Design	Single Linear Actuator
Weight Supported	Up to 136kg
VESA Supported	400mm x 400mm up to 1200mm x 600mm

Packing Dimensions			
Item no.	Descriptions	Packing Dimensions (mm)	Weight (kg.)
1	Brackets	770 x 320 x 150	15
2	Frame	1430 x 380 x 150	23
3	Extrusion	1910 x 320 x 150	24
4	Base	1280 x 850 x 100	25

Electrical Specifications	
Linear Actuator	Quantity 1 Load Capacity - 400N Speed - 4mm/s Input - 24DC Stroke Length - 500mm Retracted Length - 695mm Overload Protection - Integrated into Control Box Duty Cycle - 10% Max, 2 Min Continuous Use Material - Alloy Tube 2.5mm Operating Temp - +5deg - +40deg Certification - CE
Control Box	Output - 2 Output Voltage - 230 - 240 VAC Power - 50 Watts Certification - CE
Switch	2 Button - Up / Down Connection - Cat5 to Controller Certification - CE
Power Board	4 Way PDU Aluminum Rack Mount CE.

