

Mobile Height Adjustable System – Column Lift

The TouchBoard Mobile Height Adjustable System with Twin Lifting Columns is engineered from high tensile steel materials and designed to support modern LED touch panels up to 95kg.

The design provides an interactive panel with electronic height adjustability in the vertical position, catering for both a small and large group of users. This system also provides an inclusive learning environment for mobility impaired users.

Compact in design and having a lesser footprint than most other stands on the market, this system is the ideal solution for smaller office spaces and classrooms or shared spaces that require regular set up and pack away. Being mobile it is easily moved between areas and being height adjustable, it provides many options for the user.

A central laptop tray is included. Options include a side laptop tray, keyboard, PC and webcam mount.

- ✔ Designed to provide complete flexibility in any learning/presentation area
- ✔ Provides inclusive learning for mobility impaired users
- ✔ Perfect for Early Years, having a small footprint and able to go very low in height
- ✔ Sturdy and robust with simple electronic actuator control
- ✔ Easy to manoeuvre between areas and pack away when not required
- ✔ Rear laptop tray included. Webcam and keyboard mounts available
- ✔ Integrated power distribution board with surge protection
- ✔ Fast and easy installation process, taking under 1 hour

Height Adjustable



Panel Sizes



Dimensions Front

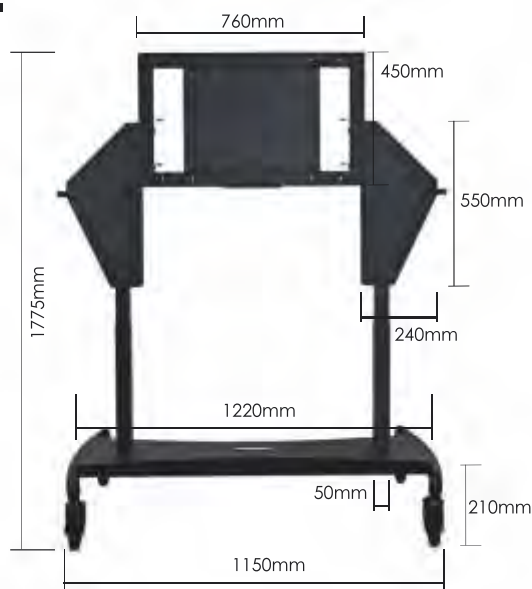

Dimensions Side



Accessories



Rear Laptop Tray



Side Laptop Tray



Keyboard Mouse Bracket



Mini PC Bracket



Web Cam Bracket



Extension Brackets to support VESA to 1000 x 600mm

Specifications

Frame Specifications	
Dimensions	Width - 750mm
	Height of Frame - 900mm to 1550mm
	Width of Base - Front 1150mm Middle 1220mm
	Depth of Base - 750mm
Material	Steel Column 2.5mm
	Steel Plate Support Brackets 3.0mm
Finish	Surface Treated Powder Coating Texture Finish to 2.0mm Thickness
Height Range	650mm of Travel
Lifting Design	Twin Lifting Column
Weight Supported	Up to 95kg
VESA Supported	400 x 400mm - 600 x 400mm. Extension Brackets to 1000 x 600mm

Packing Dimensions			
Item no.	Descriptions	Packing Dimensions (mm)	Weight (kg.)
1	Frame	800 x 520 x 180	30
2	Base	127 x 835 x 160	28
3	Actuator	760 x 335 x 180	16

Electrical Specifications	
Lifting Columns	Quantity 2
	Load Capacity - 800N
	Speed - 22mm/s
	Input - 24DC
	Stroke Length - 500mm
	Retracted Length - 650mm
	Overload Protection - Integrated into Control Box
	Duty Cycle - 10% Max, 2 Min Continuous Use
	Material - Steel 2.5mm
	Operating Temp - +5deg - +40deg
	Certification - CE
Control Box	Output - 2 Output
	Voltage - 230 - 240 VAC
	Power - 360 Watts
	Certification - CE
Switch	4 Button - Up / Down
	Connection - Cat5 to Controller
	Certification - CE
Power Board	4 Way PDU Aluminum Rack Mount CE.

